



# Chapter 6

## Digital Filter Structures

---

### Content

- ➔ Introduction
  - ➔ IIR Filter Structures
  - ➔ FIR Filter Structures
- 



# Introduction

---

## ■ What is a digital filter

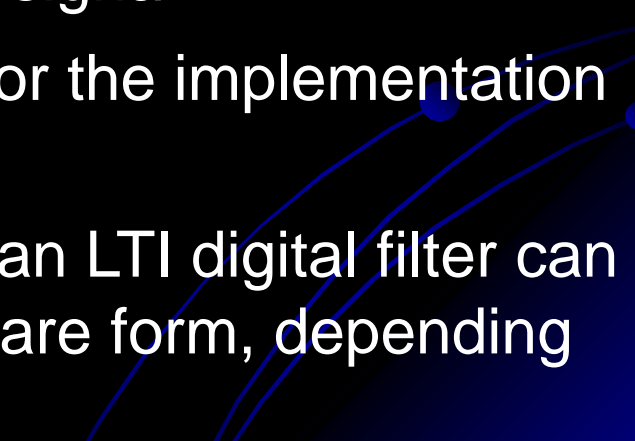
- A filter is a system that is designed to remove some component or modify some characteristic of a signal
  - A digital filter is a discrete-time LTI system which can process the discrete-time signal.
  - There are various structures for the implementation of digital filters
  - The actual implementation of an LTI digital filter can be either in software or hardware form, depending on applications
- 

# Introduction

## Basic elements of digital filter structures

- **Adder** has two inputs and one output.
- **Multiplier (gain)** has single-input, single-output.
- **Delay element** delays the signal passing through it by one sample. It is implemented by using a shift register.

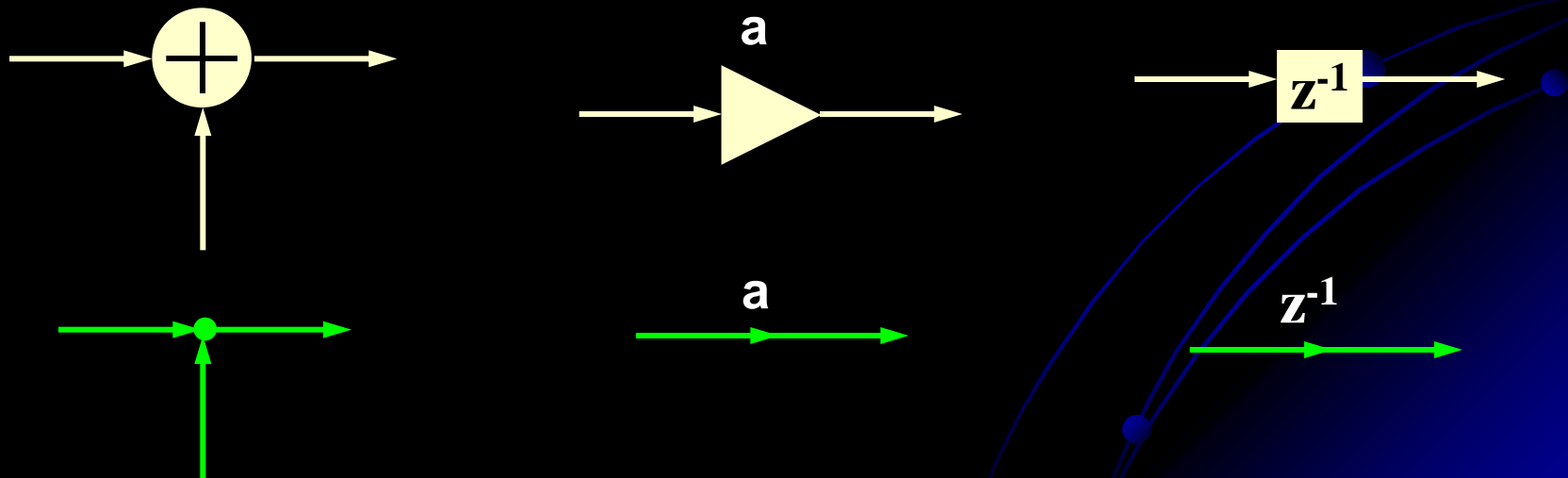

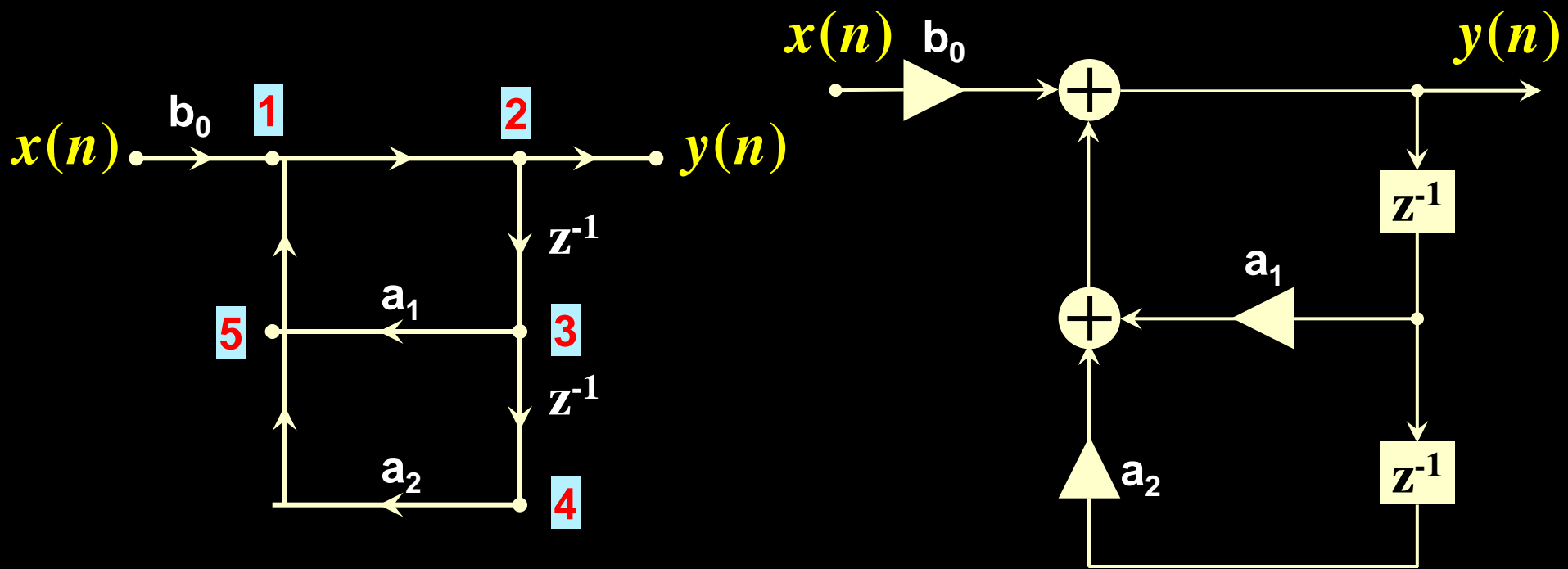

$$y(n) = b_0 x(n) + a_1 y(n-1) + a_2 y(n-2)$$

$$w_2(n) = y(n)$$

$$w_3(n) = w_2(n-1) = y(n-1)$$

$$w_4(n) = w_3(n-1) = y(n-2)$$

$$w_5(n) = a_1 w_3(n) + a_2 w_4(n) = a_1 y(n-1) + a_2 y(n-2)$$

$$w_1(n) = b_0 x(n) + w_5(n) = b_0 x(n) + a_1 y(n-1) + a_2 y(n-2)$$

# Introduction

- The major factors that influence the choice of a specific structure

- **Computational complexity**

refers to the number of arithmetic operations (multiplications, divisions, and additions) required to compute an output value  $y(n)$  for the system.

- **Memory requirements**

refers to the number of memory locations required to store the system parameters, past inputs, past outputs, and any intermediate computed values.

- **Finite-word-length effects in the computations**

refers to the quantization effects that are inherent in any digital implementation of the system, either in hardware or in software.

# IIR Filter Structures

- The characteristics of the IIR filter
- IIR filters have Infinite-duration Impulse Responses
- The system function  $H(z)$  has poles in  $0 < |z| < \infty$
- An IIR filter is a recursive system

$$H(z) = \frac{Y(z)}{X(z)} = \frac{\sum_{k=0}^M b_k z^{-k}}{1 - \sum_{k=1}^N a_k z^{-k}} = \frac{b_0 + b_1 z^{-1} + \dots + b_M z^{-M}}{1 - (a_1 z^{-1} + \dots + a_N z^{-N})}$$

$$y(n) = \sum_{k=1}^N a_k y(n-k) + \sum_{k=0}^M b_k x(n-k)$$

The *order* of such an IIR filter is called  $N$  if  $a_N \neq 0$

# IIR Filter Structures

## ■ Direct form

In this form the difference equation is implemented directly as given. There are two parts to this filter, namely the moving average part and the recursive part (or the numerator and denominator parts).

Therefore this implementation leads to two versions: direct form I and direct form II structures

$$y(n) = \sum_{k=0}^M b_k x(n-k) + \sum_{k=1}^N a_k y(n-k)$$

$$H(z) = \frac{\sum_{k=0}^M b_k z^{-k}}{1 - \sum_{k=1}^N a_k z^{-k}}$$

- Direct form I

$$y(n) = \sum_{k=0}^M b_k x(n-k) + \sum_{k=1}^N a_k y(n-k)$$

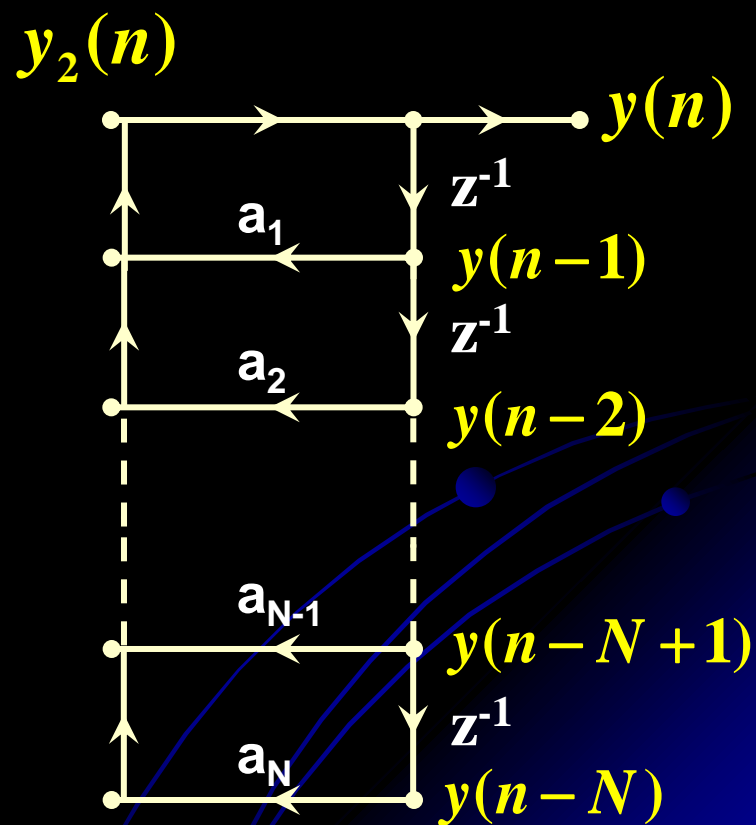
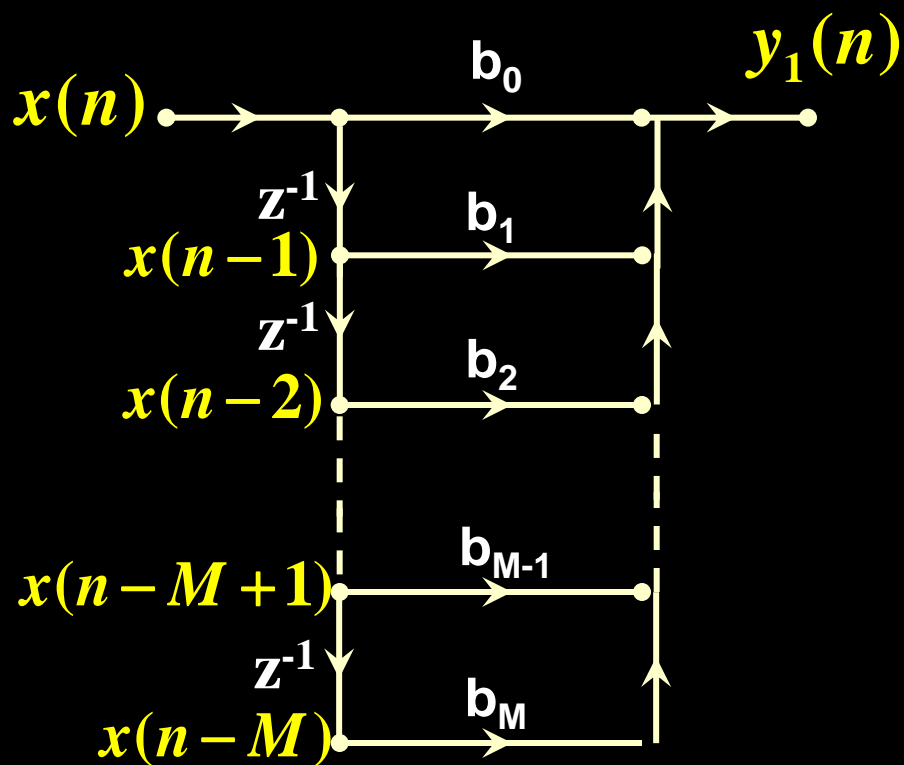



- Direct form II

For an LTI cascade system, we can change the order of the systems without changing the overall system response

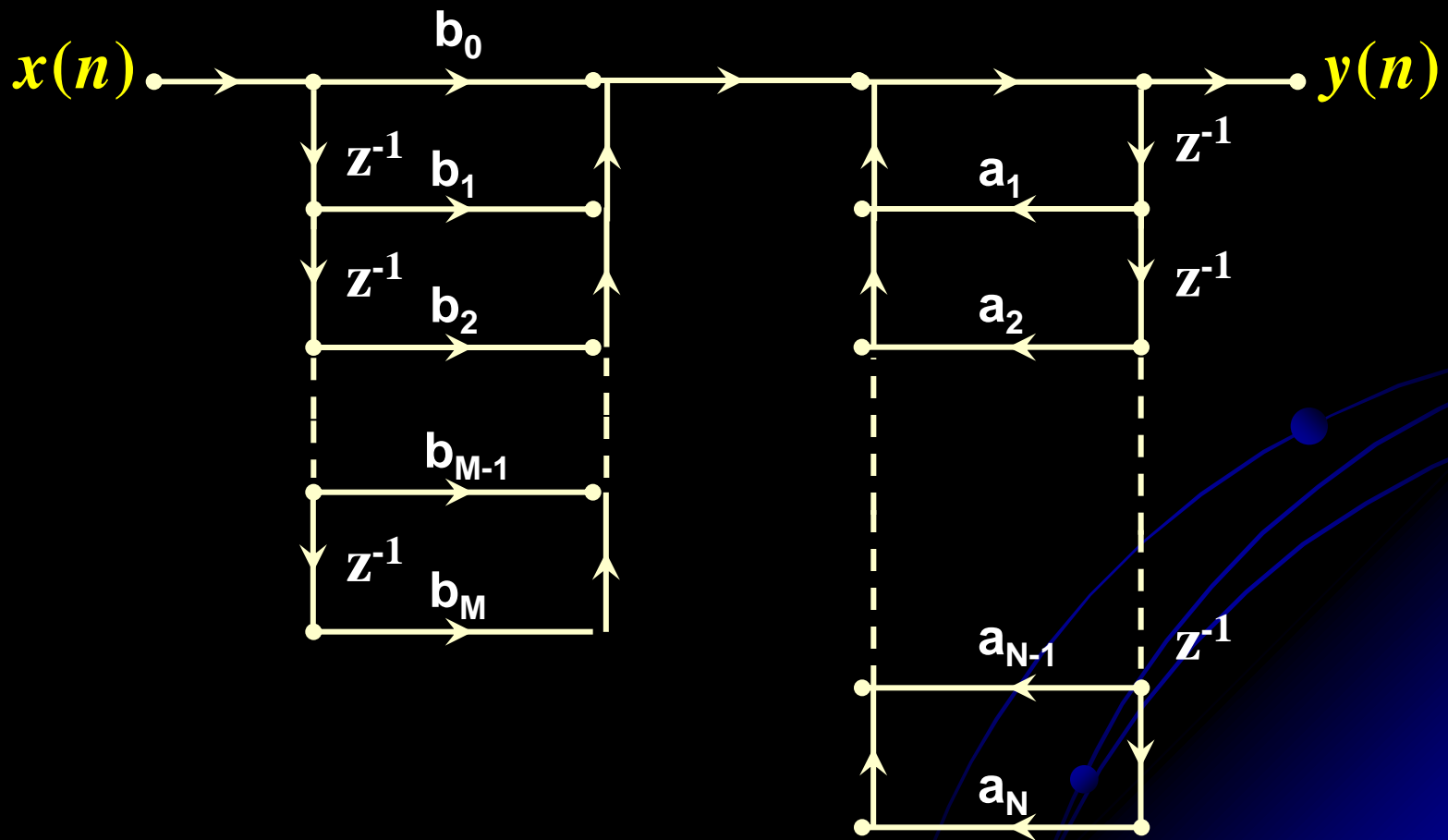

# IIR Filter Structures

## ■ Cascade form

In this form the system function  $H(z)$  is written as a product of second-order sections with real coefficients

$$H(z) = \frac{\sum_{k=0}^M b_k z^{-k}}{1 - \sum_{k=1}^N a_k z^{-k}} = A \frac{\prod_{k=1}^{M_1} (1 - p_k z^{-1}) \prod_{k=1}^{M_2} (1 - q_k z^{-1})(1 - q_k^* z^{-1})}{\prod_{k=1}^{N_1} (1 - c_k z^{-1}) \prod_{k=1}^{N_2} (1 - d_k z^{-1})(1 - d_k^* z^{-1})}$$

$$H(z) = A \frac{\prod_{k=1}^{M_1} (1 - p_k z^{-1}) \prod_{k=1}^{M_2} (1 + b_{1k} z^{-1} + b_{2k} z^{-2})}{\prod_{k=1}^{N_1} (1 - c_k z^{-1}) \prod_{k=1}^{N_2} (1 - a_{1k} z^{-1} - a_{2k} z^{-2})}$$

$$\begin{aligned} M &= M_1 + 2M_2 \\ N &= N_1 + 2N_2 \end{aligned}$$

# IIR Filter Structures

$$H(z) = A \prod_k \frac{1 + b_{1k}z^{-1} + b_{2k}z^{-2}}{1 - a_{1k}z^{-1} - a_{2k}z^{-2}} = A \prod_k H_k(z)$$

Each second-order section (called biquads) is implemented in a direct form, and the entire system function is implemented as a cascade of biquads.

- If  $N=M$ , there are totally  $\left[ \frac{N+1}{2} \right]$  biquads.
- If  $N>M$ , some of the biquads have numerator coefficients that are zero, that is, either  $b_{2k} = 0$  or  $b_{1k} = 0$  or both  $b_{2k} = b_{1k} = 0$  for some  $k$ .
- if  $N>M$  and  $N$  is odd, one of the biquads must have  $a_{k2} = 0$ , so that this biquad becomes a first-order section.

biquad

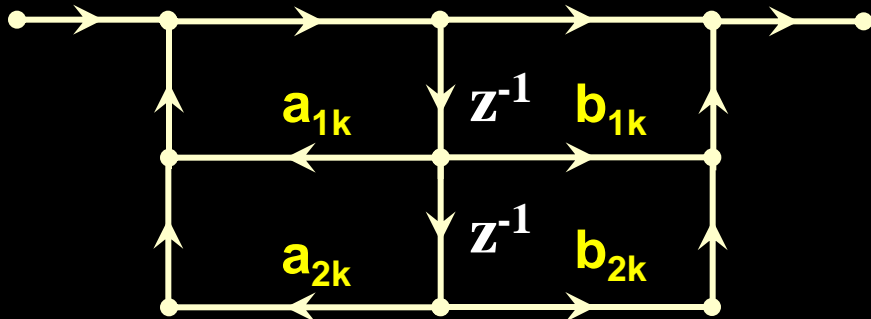

$$H_k(z) = \frac{1 + b_{1k}z^{-1} + b_{2k}z^{-2}}{1 - a_{1k}z^{-1} - a_{2k}z^{-2}}$$

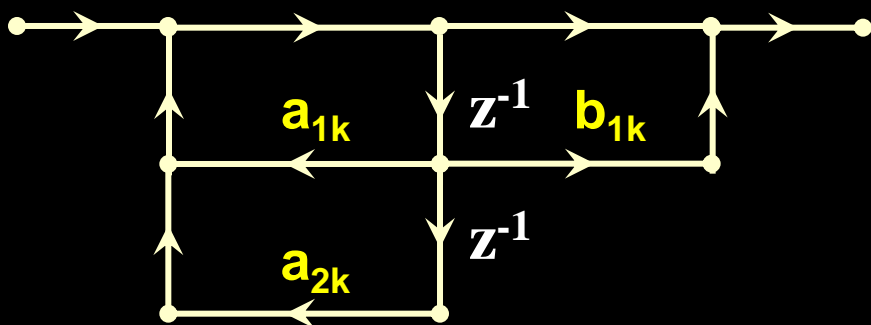

First-order section

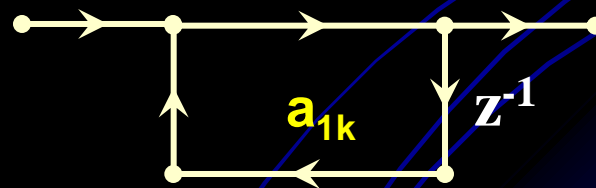
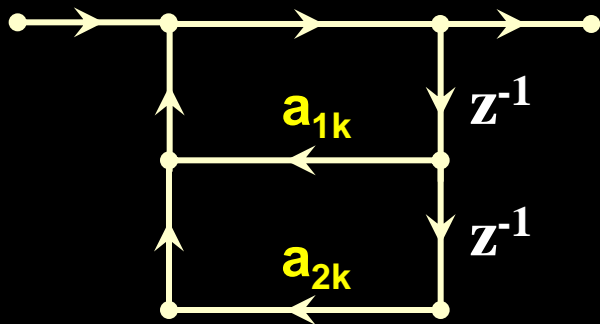
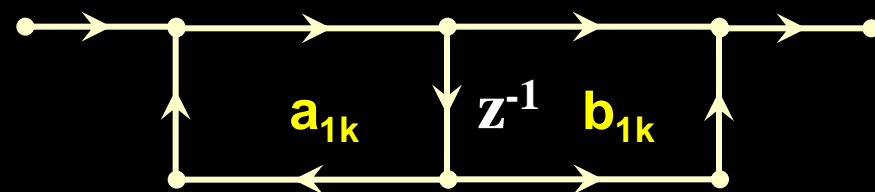

Example

$$H(z) = \frac{8 - 4z^{-1} + 11z^{-2} - 2z^{-3}}{1 - \frac{5}{4}z^{-1} + \frac{3}{4}z^{-2} - \frac{1}{8}z^{-3}}$$

$$H(z) = \frac{(2 - 0.3799z^{-1})(4 - 1.2402z^{-1} + 5.2644z^{-2})}{(1 - 0.25z^{-1})(1 - z^{-1} + 0.5z^{-2})}$$

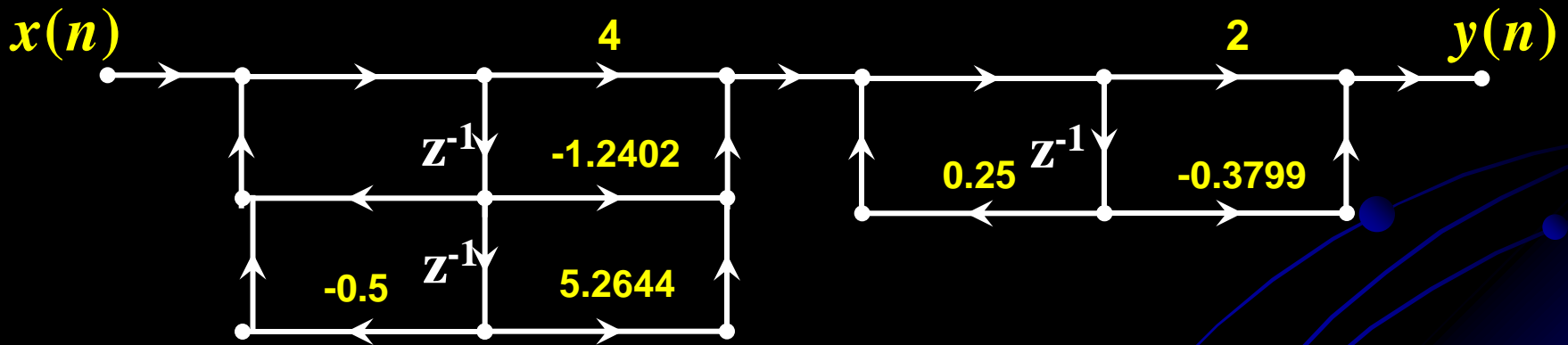

# IIR Filter Structures

## ■ Parallel form

In this form the system function  $H(z)$  is written as a sum of sections using partial fraction expansion. Each section is implemented in a direct form. The entire system function is implemented as a parallel of every section.

Suppose  $M=N$

$$H(z) = \frac{\sum_{k=0}^M b_k z^{-k}}{1 - \sum_{k=1}^N a_k z^{-k}} = G_0 + \sum_{k=1}^{N_1} \frac{A_k}{1 - c_k z^{-1}} + \sum_{k=1}^{N_2} \frac{b_{0k} + b_{1k} z^{-1}}{1 - a_{1k} z^{-1} - a_{2k} z^{-2}}$$

$$N = N_1 + 2N_2$$

# IIR Filter Structures

$$H(z) = G_0 + \sum_{k=1}^{\left\lfloor \frac{N+1}{2} \right\rfloor} \frac{b_{0k} + b_{1k}z^{-1}}{1 - a_{1k}z^{-1} - a_{2k}z^{-2}}$$

- if  $N$  is odd, the system has one first-order section and  $\frac{N-1}{2}$  second-order sections.
- if  $N$  is even, the system has  $\frac{N}{2}$  second-order sections.

# Example

$$H(z) = \frac{10(1 - \frac{1}{2}z^{-1})(1 - \frac{2}{3}z^{-1})(1 + 2z^{-1})}{(1 - \frac{3}{4}z^{-1})(1 - \frac{1}{8}z^{-1}) \left[ 1 - (\frac{1}{2} + j\frac{1}{2})z^{-1} \right] \left[ 1 - (\frac{1}{2} - j\frac{1}{2})z^{-1} \right]}$$

$$H(z) = \frac{A_1}{(1 - \frac{3}{4}z^{-1})} + \frac{A_2}{(1 - \frac{1}{8}z^{-1})} + \frac{A_3}{1 - (\frac{1}{2} + j\frac{1}{2})z^{-1}} + \frac{A_4}{1 - (\frac{1}{2} - j\frac{1}{2})z^{-1}}$$

$$A_1 = 2.93, \quad A_2 = -17.68, \quad A_3 = 12.25 - j14.57, \quad A_4 = 12.25 + j14.57$$

$$H(z) = \frac{-14.75 - 12.90z^{-1}}{1 - \frac{7}{8}z^{-1} + \frac{3}{32}z^{-2}} + \frac{24.50 + 26.82z^{-1}}{1 - z^{-1} + \frac{1}{2}z^{-2}}$$



$$H(z) = \frac{-14.75 - 12.90z^{-1}}{1 - \frac{7}{8}z^{-1} + \frac{3}{32}z^{-2}} + \frac{24.50 + 26.82z^{-1}}{1 - z^{-1} + \frac{1}{2}z^{-2}}$$

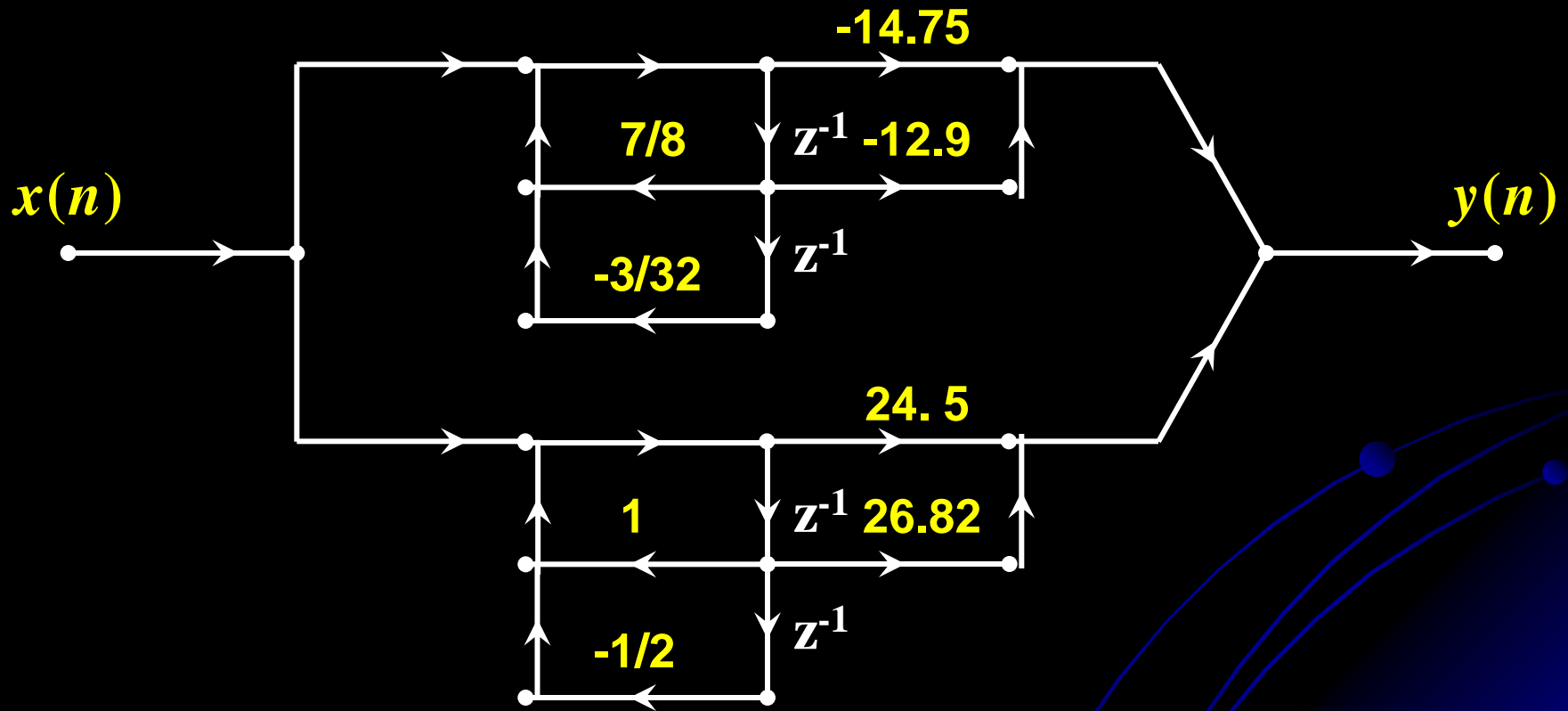



# IIR Filter Structures

- Transposition theorem

If we reverse the directions of all branch transmittances and interchange the input and output in the flow graph, the system function remains unchanged.

The resulting structure is called a *transposed structure* or a *transposed form*.

# FIR Filter Structures

## ■ The characteristics of the FIR filter

- FIR filters have **F**inite-duration **I**mpulse **R**esponses, thus they can be realized by means of DFT
- The system function  $H(z)$  has the **ROC** of  $|z| > 0$ , thus it is a causal system
- An FIR filter is a nonrecursive system
- FIR filters can be designed to have a linear-phase response

$$H(z) = \sum_{n=0}^{N-1} h(n)z^{-n}$$

It has  $N-1$  order poles at  $z = 0$   
and  $N-1$  zeros in  $|z| > 0$

The *order* of such an FIR filter is  $N-1$

# FIR Filter Structures

## ■ Direct form

In this form the difference equation is implemented directly as given.

$$y(n] = \sum_{m=0}^{N-1} h(m)x(n-m)$$

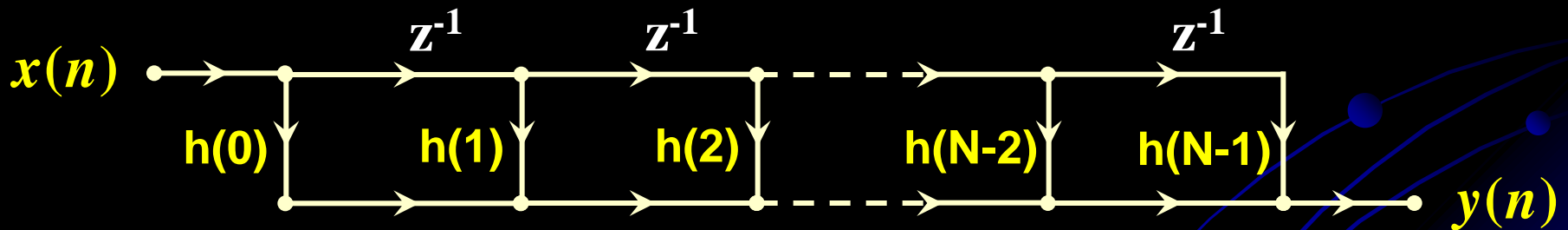

It requires  $N$  multiplications

# FIR Filter Structures

## ■ Cascade form

In this form the system function  $H(z)$  is converted into products of second-order sections with real coefficients

$$H(z) = \sum_{n=0}^{N-1} h(n)z^{-n} = \prod_{k=1}^{\left\lfloor \frac{N}{2} \right\rfloor} (b_{0k} + b_{1k}z^{-1} + b_{2k}z^{-2})$$

It requires  $(3N/2)$  multiplications

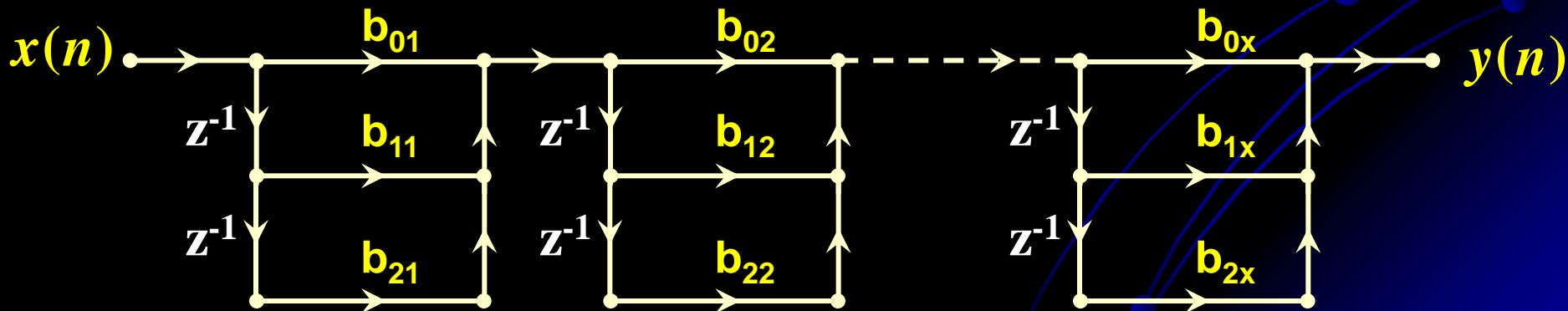

# FIR Filter Structures

## ■ Linear-phase form

### ● Linear phase:

The phase response is a linear function of frequency

### ● Linear-phase condition

$h(n) = h(N - 1 - n)$  Symmetric impulse response

$h(n) = -h(N - 1 - n)$  Antisymmetric impulse response

● When an FIR filter has a linear phase response, its impulse response exhibits the above symmetry conditions. In this form we exploit these symmetry relations to reduce multiplications by about half.

If  $N$  is odd

$$H(z) = \sum_{n=0}^{N-1} h(n)z^{-n}$$

$$= \sum_{n=0}^{\frac{N-1}{2}-1} h(n)z^{-n} + h\left(\frac{N-1}{2}\right)z^{-\frac{N-1}{2}} + \sum_{n=\frac{N-1}{2}+1}^{N-1} h(n)z^{-n}$$

$$= \sum_{n=0}^{\frac{N-1}{2}-1} h(n)z^{-n} + h\left(\frac{N-1}{2}\right)z^{-\frac{N-1}{2}} + \sum_{m=0}^{\frac{N-1}{2}-1} h(N-1-m)z^{-(N-1-m)}$$

**let  $n = N-1-m$**

$$= \sum_{n=0}^{\frac{N-1}{2}-1} h(n)[z^{-n} \pm z^{-(N-1-n)}] + h\left(\frac{N-1}{2}\right)z^{-\frac{N-1}{2}}$$

**let  $n \leftarrow m$**

$$\mathbf{h(n) = \pm h(N-1-n)}$$

If  $N$  is odd

$$H(z) = \sum_{n=0}^{\frac{N-1}{2}-1} h(n) [z^{-n} \pm z^{-(N-1-n)}] + h\left(\frac{N-1}{2}\right) z^{-\frac{N-1}{2}}$$

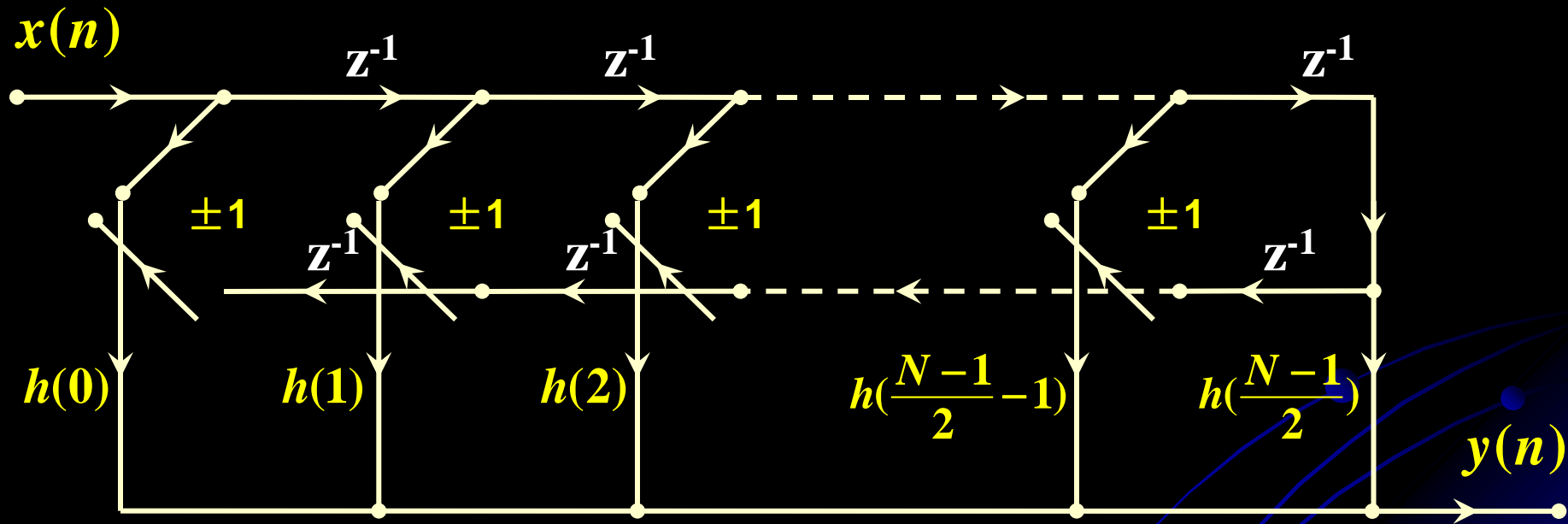

1 for symmetric  
-1 for antisymmetric



If  $N$  is even

$$H(z) = \sum_{n=0}^{N-1} h(n)z^{-n} = \sum_{n=0}^{\frac{N}{2}-1} h(n)z^{-n} + \sum_{n=\frac{N}{2}}^{N-1} h(n)z^{-n}$$

$$= \sum_{n=0}^{\frac{N}{2}-1} h(n)z^{-n} + \sum_{m=0}^{\frac{N}{2}-1} h(N-1-m)z^{-(N-1-m)}$$

**let  $n = N-1-m$**

$$= \sum_{n=0}^{\frac{N}{2}-1} h(n)[z^{-n} \pm z^{-(N-1-n)}]$$

**let  $n \leftarrow m$**

**$h(n) = \pm h(N-1-n)$**

If  $N$  is even

$$H(z) = \sum_{n=0}^{\frac{N}{2}-1} h(n) [z^{-n} \pm z^{-(N-1-n)}]$$

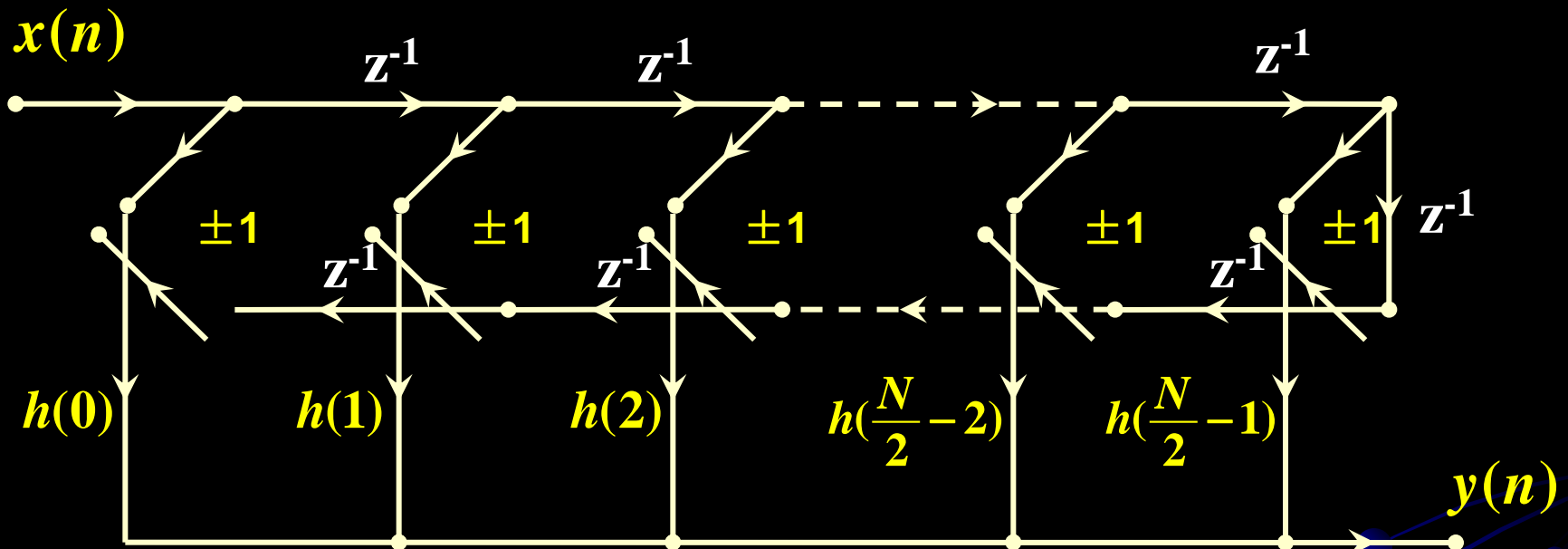

1 for symmetric  
-1 for antisymmetric

The linear-phase filter structure requires 50% fewer multiplications than the direct form.

# FIR Filter Structures

- Frequency sampling form

This structure is based on the DFT of the impulse response  $h(n)$  and leads to a parallel structure. It is also suitable for a design technique based on the sampling of frequency response  $H(z)$

$$H(z) = (1 - z^{-N}) \frac{1}{N} \sum_{k=0}^{N-1} \frac{H(k)}{1 - W_N^{-k} z^{-1}} = \frac{1}{N} H_c(z) \sum_{k=0}^{N-1} H'_k(z)$$

$$H_c(z) = 1 - z^{-N}$$

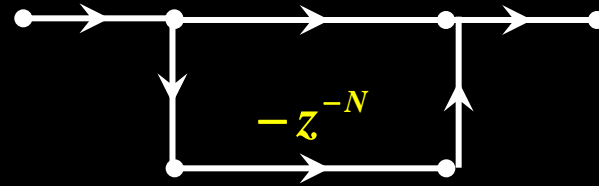

It has  $N$  equally spaced zeros on the unit circle

$$z_k = e^{j\frac{2\pi}{N}k}, \quad k = 0, 1, \dots, N-1$$

$$H_c(e^{j\omega}) = 1 - e^{-j\omega N} = 2je^{-j\frac{\omega N}{2}} \sin\left(\frac{\omega N}{2}\right)$$

$$|H_c(e^{j\omega})| = 2 \left| \sin\left(\frac{\omega N}{2}\right) \right|$$

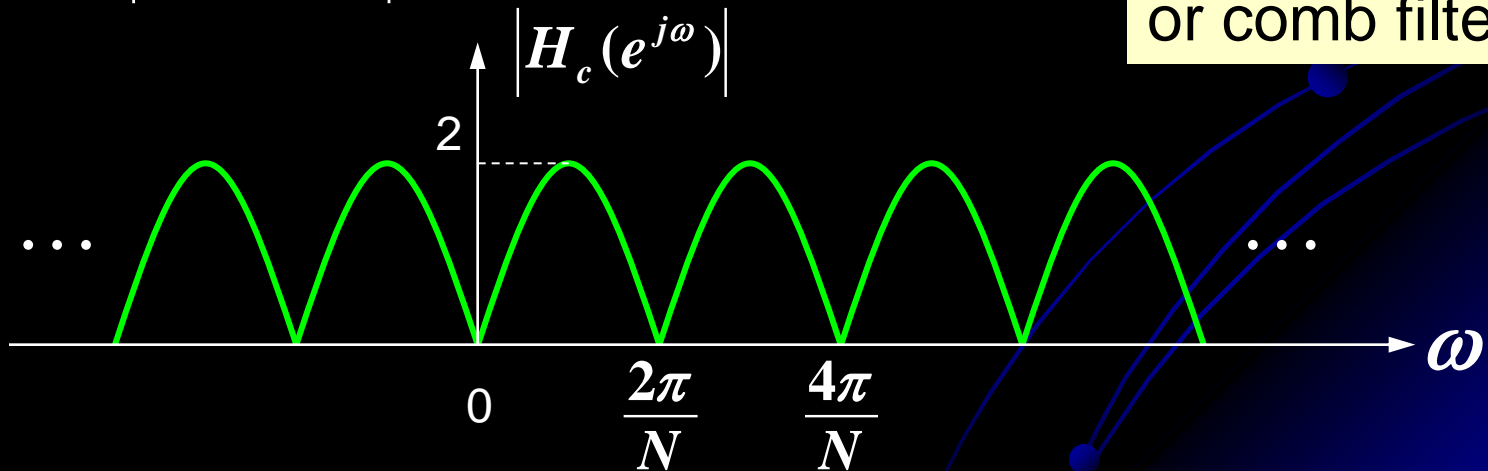

All-zero filter  
or comb filter

$$\sum_{k=0}^{N-1} H'_k(z) = \sum_{k=0}^{N-1} \frac{H(k)}{1 - W_N^{-k} z^{-1}}$$

resonant filter

It has  $N$  equally spaced poles on the unit circle

$$z_k = e^{j\frac{2\pi}{N}k}, \quad k = 0, 1, \dots, N-1$$

The pole locations are identical to the zero locations and that both occur at  $\omega = \frac{2\pi}{N}k$ , which are the frequencies at which the designed frequency response is specified. The gains of the filter at these frequencies are simply the complex-valued parameters  $H(k)$

$$H(z) = (1 - z^{-N}) \frac{1}{N} \sum_{k=0}^{N-1} \frac{H(k)}{1 - W_N^{-k} z^{-1}} = \frac{1}{N} H_c(z) \sum_{k=0}^{N-1} H'_k(z)$$

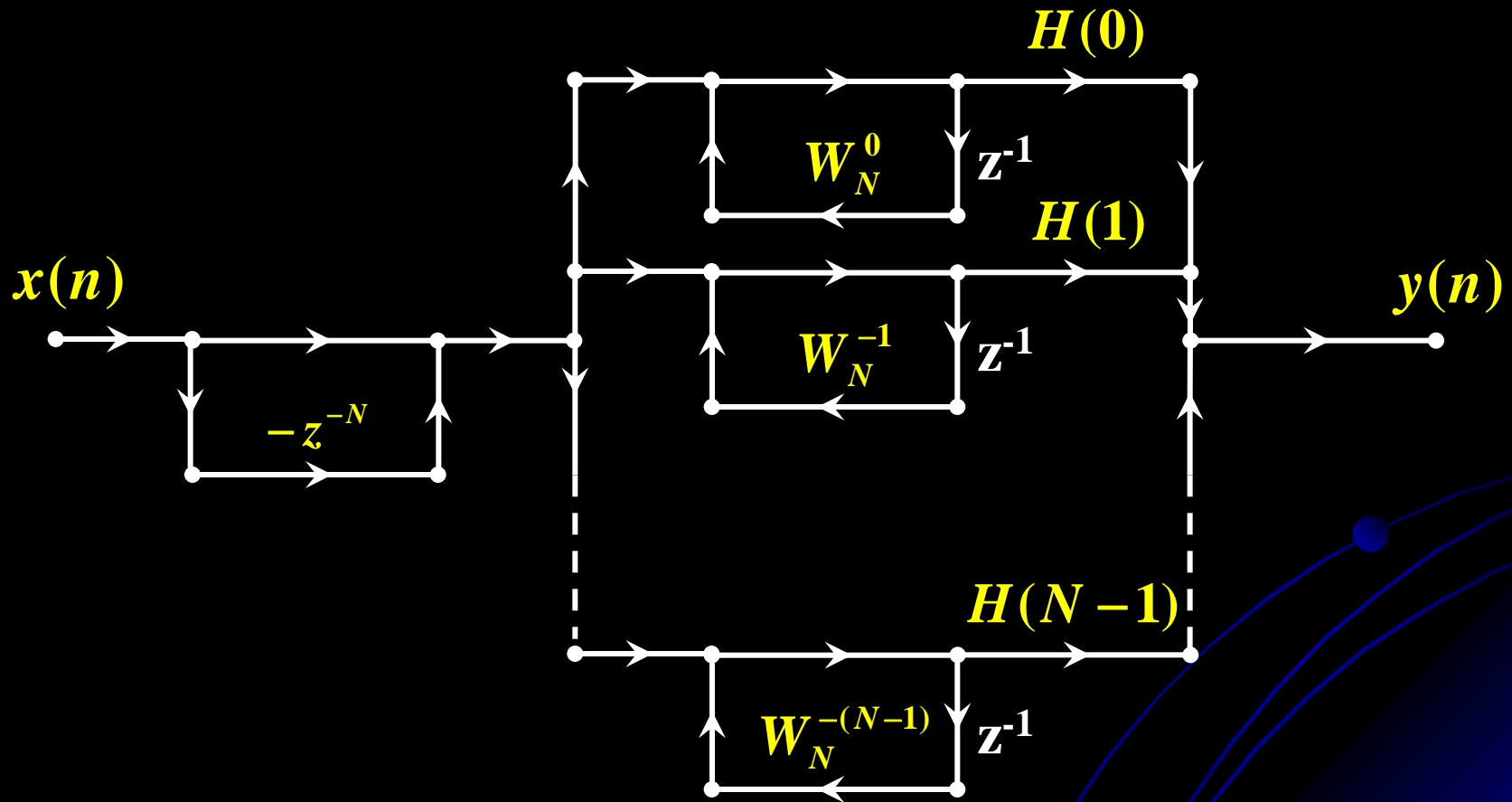



# FIR Filter Structures

## Problems

- It requires a complex arithmetic implementation

It is possible to obtain an alternate realization in which only real arithmetic is used. This realization is derived using the symmetric properties of the DFT and the  $W_N^{-k}$  factor.

- It has poles on the unit circle, which makes this filter critically unstable

We can avoid this problem by sampling  $H(z)$  on a circle  $|z|=r$  where the radius  $r$  is very close to one but is less than one.

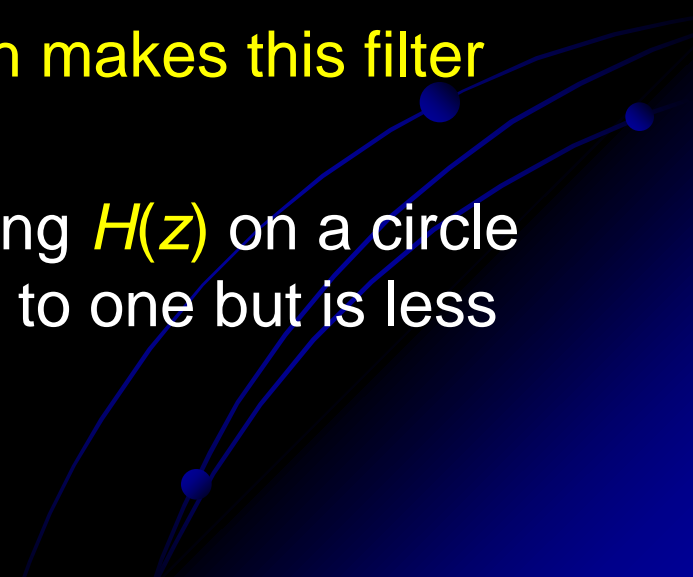

$$H(z) = \frac{1-z^{-N}}{N} \sum_{k=0}^{N-1} \frac{H(k)}{1-W_N^{-k} z^{-1}}$$

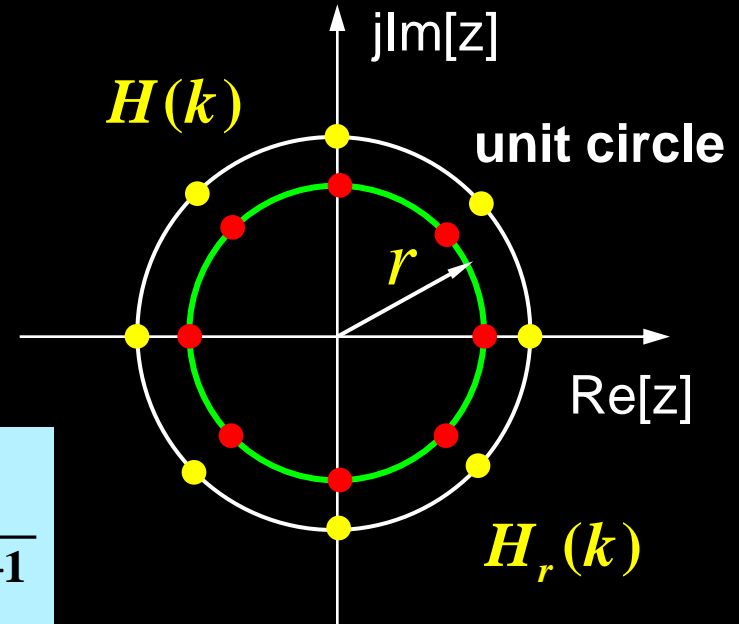

$$H(z) = \frac{1-r^N z^{-N}}{N} \sum_{k=0}^{N-1} \frac{H_r(k)}{1-rW_N^{-k} z^{-1}}$$

$$H_r(k) \approx H(k)$$

$$H(z) \approx \frac{1-r^N z^{-N}}{N} \sum_{k=0}^{N-1} \frac{H(k)}{1-rW_N^{-k} z^{-1}}$$



$$H(z) \approx \frac{1 - r^N z^{-N}}{N} \sum_{k=0}^{N-1} \frac{H(k)}{1 - r W_N^{-k} z^{-1}}$$

By using the symmetric properties of the **DFT** and the  $W_N^{-k}$  factor, a pair of single-pole filters can be combined to form a single two-pole filter with real-valued parameters.

For poles  $z_k = e^{j\frac{2\pi}{N}k}$ ,  $k = 0, 1, \dots, N-1$

$$z_{N-k} = z_k^*$$

$$r W_N^{-(N-k)} = r e^{j\frac{2\pi}{N}(N-k)} = r (e^{j\frac{2\pi}{N}k})^* = r (W_N^{-k})^* = r W_N^k$$

$h(n)$  is a real-valued sequence, so

$$H(k) = H^*((N-k))_N R_N(k)$$

So the  $k^{\text{th}}$  and  $(N-k)^{\text{th}}$  resonant filters can be combined to form a second-order section  $H_k(z)$  with real-valued coefficients

$$\begin{aligned}
 H_k(z) &= \frac{H(k)}{1 - rW_N^{-k}z^{-1}} + \frac{H(N-k)}{1 - rW_N^{-(N-k)}z^{-1}} \\
 &= \frac{H(k)}{1 - rW_N^{-k}z^{-1}} + \frac{H^*(k)}{1 - rW_N^kz^{-1}} = \frac{b_{0k} + b_{1k}z^{-1}}{1 - z^{-1}2r \cos\left(\frac{2\pi}{N}k\right) + r^2z^{-2}}
 \end{aligned}$$

$$\begin{cases}
 k = 1, 2, \dots, \frac{N-1}{2}, N \text{ is odd} \\
 k = 1, 2, \dots, \frac{N}{2} - 1, N \text{ is even}
 \end{cases}$$

$$b_{0k} = 2 \operatorname{Re}[H(k)]$$

$$b_{1k} = -2r \operatorname{Re}[H(k)W_N^k]$$

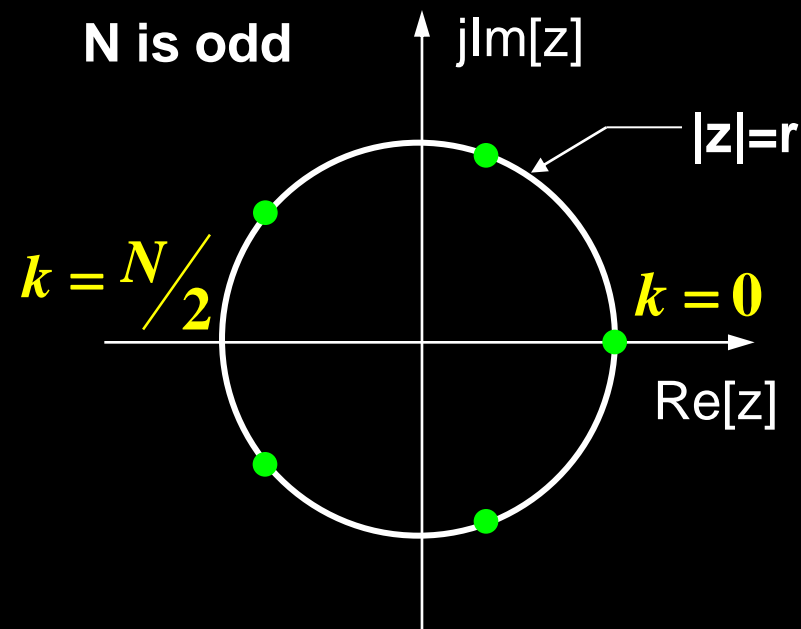
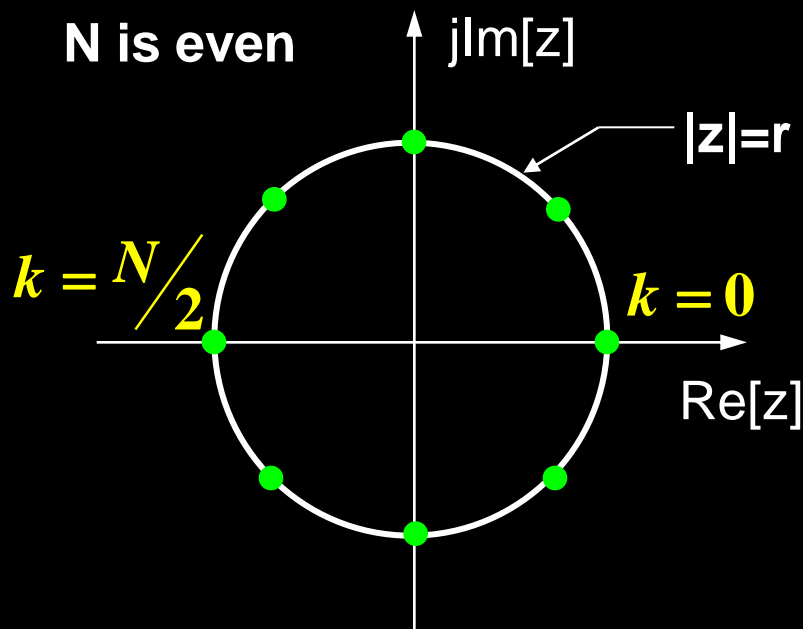

If N is even, the filter has a pair of real-valued poles  $z = \pm r$

$$H_0(z) = \frac{H(0)}{1 - rz^{-1}} \quad H_{N/2}(z) = \frac{H(N/2)}{1 + rz^{-1}}$$

If N is odd, the filter has a single real-valued pole  $z = r$

$$H_0(z) = \frac{H(0)}{1 - rz^{-1}}$$

# second-order section

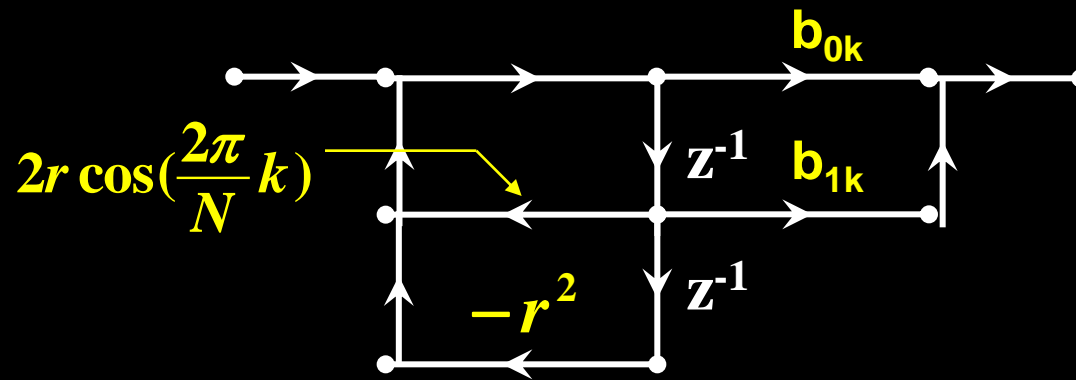

# first-order sections

$$H_0(z)$$

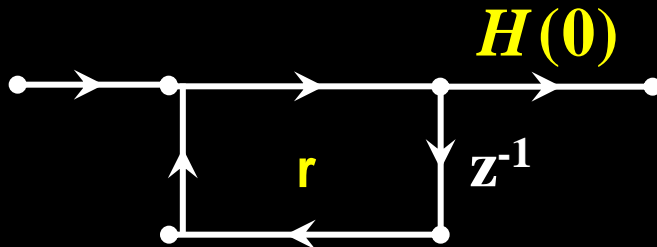

$$H_{N/2}(z)$$

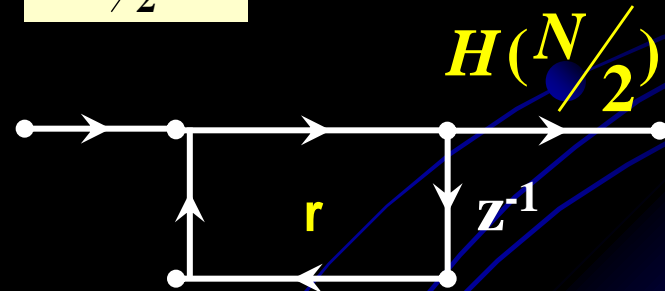

N is even

$$H(z) = \frac{1 - r^N z^{-N}}{N} \left[ H_0(z) + H_{N/2}(z) + \sum_{k=1}^{N/2-1} H_k(z) \right]$$

N is odd

$$H(z) = \frac{1 - r^N z^{-N}}{N} \left[ H_0(z) + \sum_{k=1}^{(N-1)/2} H_k(z) \right]$$

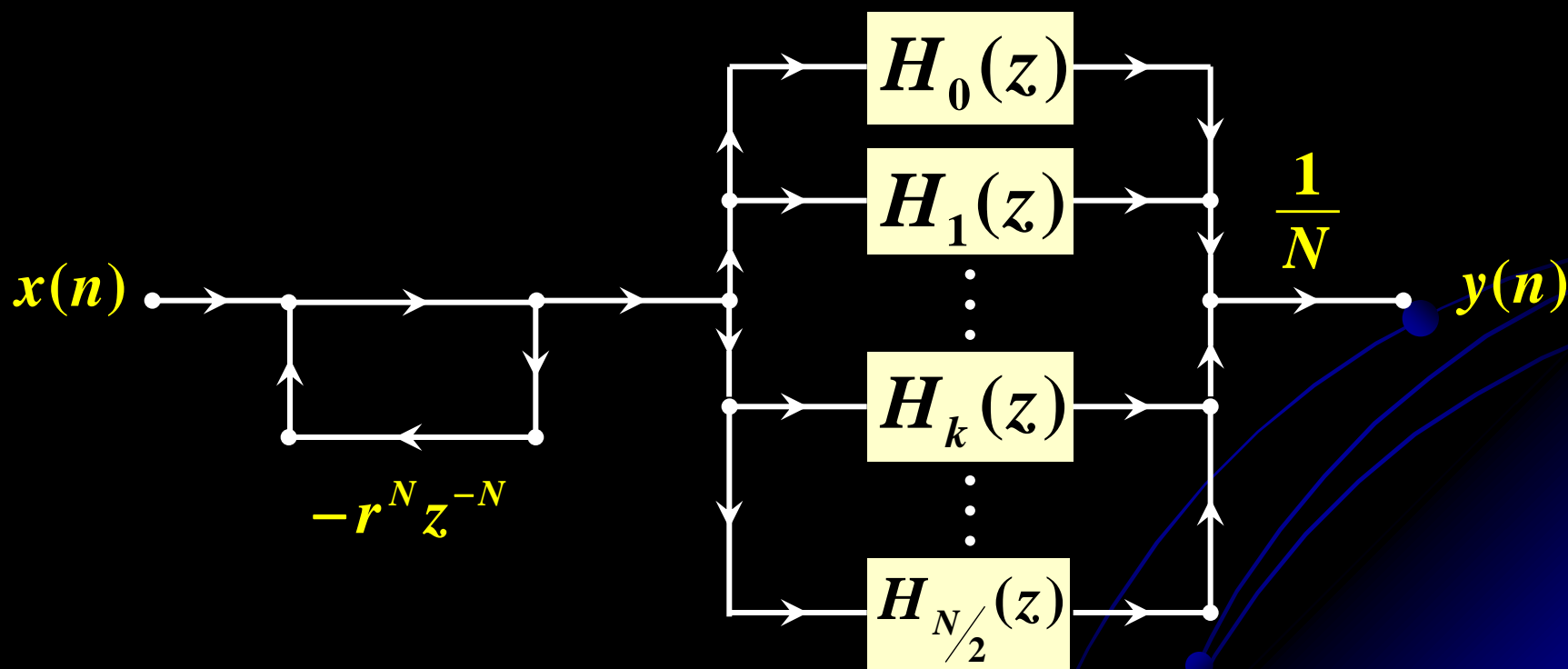

# FIR Filter Structures

- Fast convolution form

$x(n)$ :  $N_1$ -point sequence

$h(n)$ :  $N_2$ -point sequence

$$L \geq N_1 + N_2 - 1$$

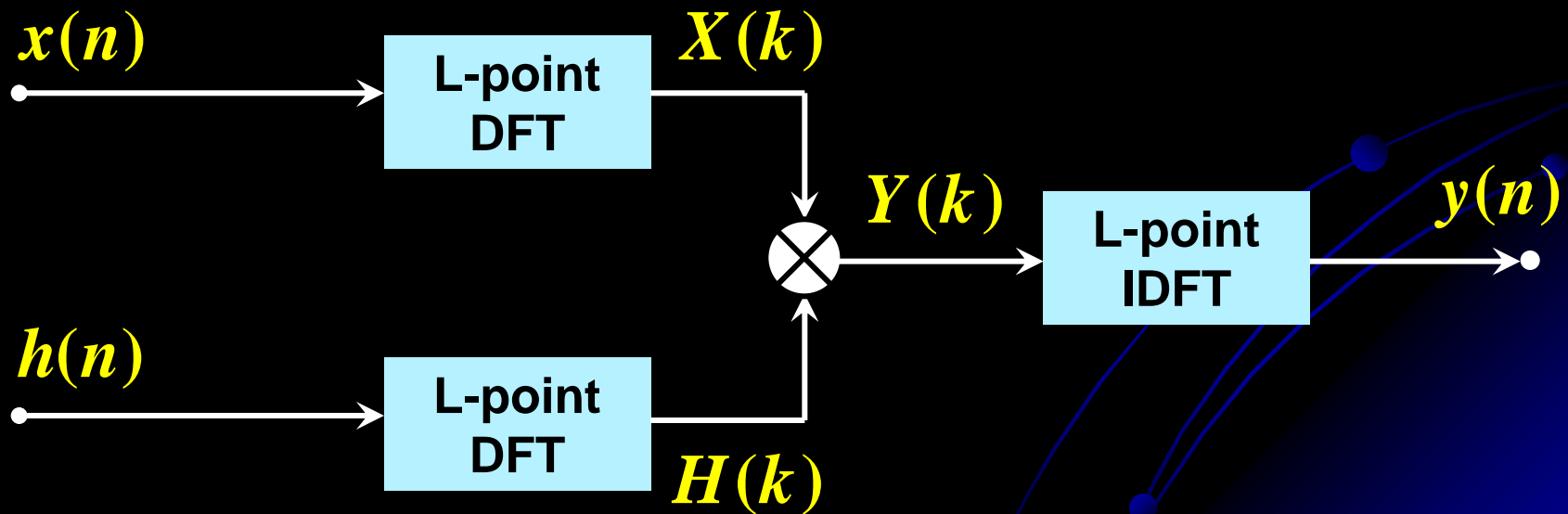

$$h(n)=h(N-1-n)$$

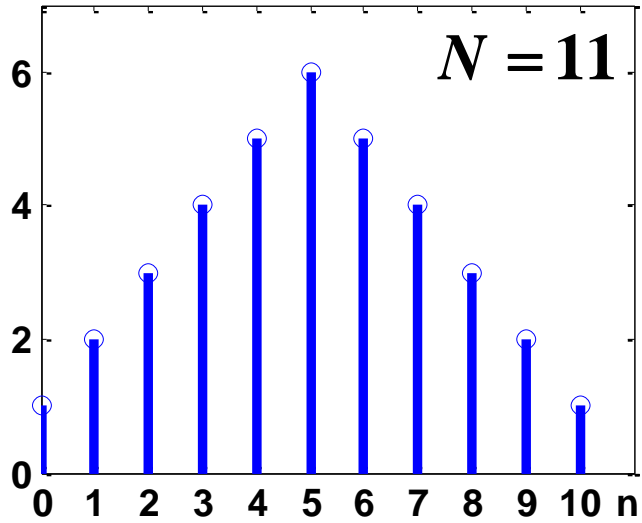

$$h(n)=-h(N-1-n)$$

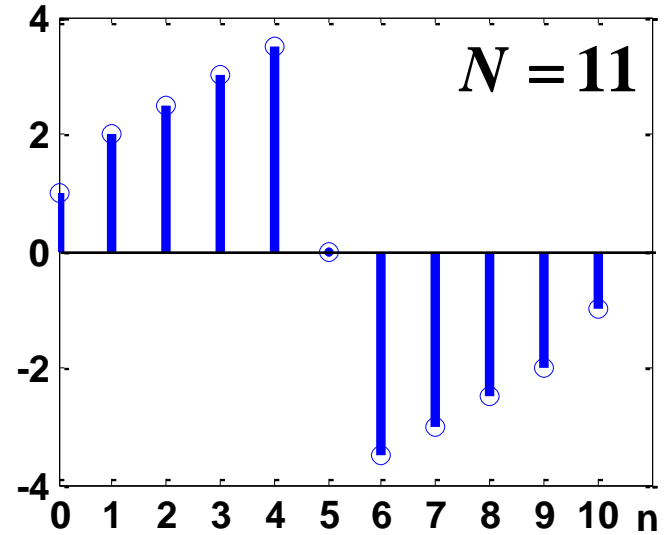

$$h(n)=h(N-1-n)$$

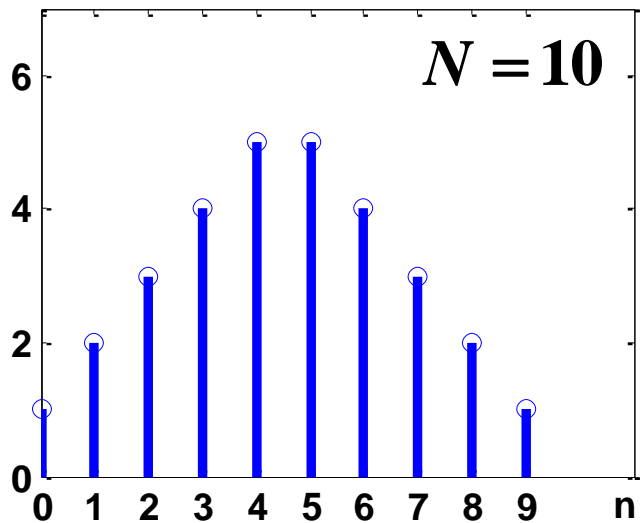

$$h(n)=-h(N-1-n)$$

